

# Pallet Truck with Scale

Streamlining material transport with ease, electric trucks offer consistency and control and can be used across a range of industries, adaptable to different warehouse or logistical setups.

- **Weighing Capability & Thermal Printer Functionality:** Tech feature allows users to weigh loads directly without needing a scale and the option to print weight or load info immediately after weighing. Features a thermal printer that doesn't require color band replacement for added convenience.
- **Streamlined Interface with Enhanced Readability:** User-friendly and straightforward operational interface. Features a 6-digit LCD display angled for easy reading by operators. Offers 0.1% maximum error value and 0.5kg weighing accuracy.
- **Unit Flexibility:** Incorporates five intuitive buttons for effortless operation and simplified functionality. Effortlessly toggles weighing units (kg/lb) to meet diverse market requirements.
- **Smart Backlighting:** Automatic backlight activation upon weight changes for operator convenience. Backlight switches off after weight stabilization to conserve energy.
- **Robust Protection & Enhanced Connectivity:** Iron plate shielding safeguards the instrument from operational bumps and damage. Totally enclosed rear with aviation connector/RS232 connector for improved instrument protection.
- **Long-lasting Power:** Powered by a 4.8V/4AH lithium battery for over 60 hours of continuous use, 300 hours on standby, with a quick 5-hour recharge.

For more information, please visit: [www.linconson.com](http://www.linconson.com)

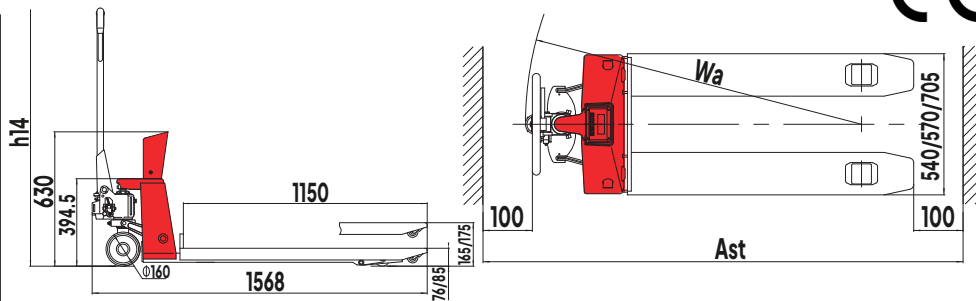

Figure 1.



# Manual Pallet Truck Model LI-HPTS



Smooth Transit, Seamless Control  
Pallet Trucks by Linconson Industries

<b>Model</b>	<b>LI-HPTS</b>
<b>Capacity</b>	<b>2000 (kg)   4409.2(lb)</b>
<b>Lowered fork height</b>	<b>76/ 85 (mm)   3/ 3.3 (in)</b>
<b>Total lift height</b>	<b>165/ 175 (mm)   6.5/ 6.9 (in)</b>
<b>Fork length</b>	<b>1150 (mm)   3 ft 9.3 in</b>
<b>Width fork overall</b>	<b>540/ 570/ 705 (mm)   1 ft 9.3 in/ 1 ft 10.4 in/ 2 ft 3.8 in</b>
<b>Steering wheel</b>	<b>Φ160 (mm)   Φ6.3 (in)</b>
<b>Fork wheel</b>	<b>Φ70 mm   Φ2.8 (in)</b>
<b>Power</b>	<b>4.8V/ 4Ah li-ion battery</b>
<b>Max. deviation (weight)</b>	<b>0.5 (kg)   1.1 (lb)</b>
<b>Max. deviation (rate)</b>	<b>±0.1%</b>
<b>Turning radius</b>	<b>1368 (mm)   4 ft 5.9 in</b>
<b>Service weight</b>	<b>115 - 130 (kg)   253.5 - 286.6 (lb)</b>

**\*Refer to Figure 1. for additional info for abbreviation references (eg. h14).**