

Electric Stacker

The unique counter-balanced design provides optimized load lifting without requiring additional supports like extended legs, making it more maneuverable in tight spaces.

Enhanced Design And Functionality:

- Mast is crafted with specially imported German steel for durable construction. Dual lifting cylinders on the mast's exterior ensure stability and efficiency.
- Incorporates a lengthy handle for effortless maneuverability and agility. Also features a vertical driving wheel for efficient operation and maintenance.
- Compact build with a low center of gravity ensures stability during handling.

Safety, Performance & Maintenance Advantages:

- Utilizes an AC frequency conversion traction motor for high performance, regenerative braking, and easy maintenance. Integrates magnetic and regenerative brakes for enhanced durability and preservation of friction plates.
- Includes ergonomic controls like an emergency stop switch, electricity lock button, and a multiple valve control system with an adjustable regulator valve that can adjust mast lowering speeds.
- Forks equipped with a tilting system facilitate easy loading and stacking. Stacker works on an AC controlling system, requiring minimal upkeep.
- Employs a high-capacity storage battery with a battery discharge indicator and a magnetically suctioned battery cover for an extended lifespan and simplified maintenance.

For more information, please visit: www.linconson.com

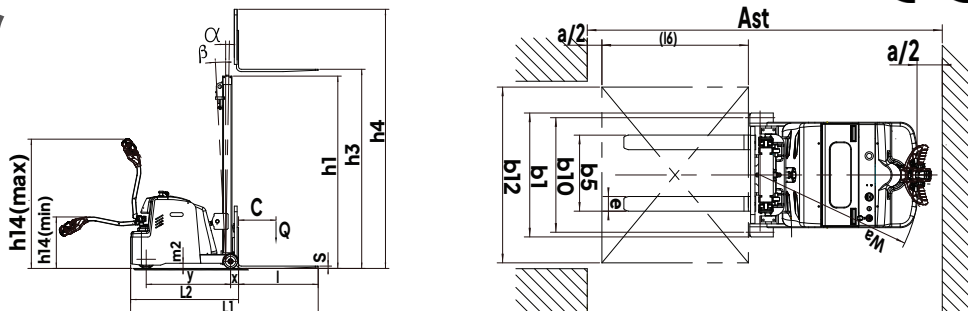

Figure 1 .



Electric Stacker Model LI-CBESX0-X



Versatile Stacking Solutions
Stackers by Linconson Industries

	Model	LI-CBES30-05	LI-CBES30-1	LI-CBES30-15	
General Information	Drive: electric (battery type, mains, ...), diesel, petrol, fuel gas	Electric	Electric	Electric	
	Operator type: hand, pedestrian, standing, seated, order-picker	Pedestrian	Pedestrian	Pedestrian	
	Rated capacity/rated load	Q	550 (kg) 1212.5 (lb)	1000 (kg) 2204.6 (lb)	1500 (kg) 3306.9 (lb)
	Load centre distance	C	400(mm) 1 ft 3.7 in	400 (mm) 1 ft 3.7 in	500 (mm) 1 ft 7.7 in
	Load distance, centre of drive axle to fork	X	90 (mm) 3.5 (in)	90 (mm) 3.5 (in)	130 (mm) 5.1 (in)
	Wheelbase	y	900 (mm) 2 ft 11.4 in	1150 (mm) 3 ft 9.3 in	1380 (mm) 4 ft 6.3 in
Weight	Axle loading, laden front/rear	380/ 495 (kg) 837.8/1091.3 (lb)	430/ 750 (kg) 948/ 1653.5 (lb)	460/ 3120 (kg) 1014.1/ 6878.4 (lb)	
	Axle loading, unladen front/rear	1175/ 250 (kg) 2590.4/ 551.2 (lb)	1856/ 324 (kg) 4091.8/ 714.3 (lb)	1080/ 1000 (kg) 2381/ 2204.6 (lb)	
	Tires: solid rubber, superelastic, pneumatic, polyurethane	Polyurethane (PU)	Polyurethane (PU)	Polyurethane (PU)	
	Tire size, front	Φ150× 64 (mm) Φ5.9× 2.5(in)	Φ150× 64 (mm) Φ5.9× 2.5(in)	Φ250× 70 (mm) Φ9.8× 2.8 (in)	
	Tire size, rear	Φ195×70 (mm) 7.7×2.8 (in)	Φ195×70 (mm) Φ7.7×2.8 (in)	Φ200×100 (mm) Φ7.9×3.9 (in)	
Tires	Wheels, number front/rear (x = driven wheels)	1x + 2	1x + 2	1x + 2	
	Tread, front	b10	782 (mm) 2 ft 6.8 in	782 (mm) 2 ft 6.8 in	890 (mm) 2 ft 11 in
	Tread, rear		0	0	0
	Tilt of mast/fork carriage forward/backward	a/b (°)	1/3	1/3	3/ 6
	Height, mast lowered	h1	2052 (mm) 6 ft 8.8 in	2052 (mm) 6 ft 8.8 in	1895/ 2085/ 2235/ 2435 (mm) 6ft 2.6in/ 6 ft 10.1 in/ 7 ft 4in/ 7 ft 11.9 in
Dimensions	Free lift		0 0	0 0	1400/ 1500/ 1670/ 1870 (mm) 4 ft 7.1 in/ 4 ft 11.1 in/ 5 ft 5.7/ 6 ft 1.6 in
	Max. lift height	h3	3000 (mm) 9 ft 10.1 in	3000 (mm) 9 ft 10.1 in	4000/ 4500/ 5000/ 5600 (mm) 13 ft 1.5 in/ 14 ft 9.2 in/ 16 ft 4.9 in/ 18 ft 4.5 in
	Height, mast extended	h4	3640 (mm) 11 ft 11.3 in	3640 (mm) 11 ft 11.3 in	5000/ 5500/ 6000/ 6600 (mm) 16 ft 4.9 in/ 18ft 0.5 in/ 19 ft 8.2/ 21 ft 7.8 in
	Height drawbar in driving position min./max.	L1	670/ 1300 (mm) 2 ft 2.4 in/ 4 ft 3.2 in	670/ 1300 (mm) 2 ft 2.4 in/ 4 ft 3.2 in	730/ 1360 (mm) 2 ft 4.7 in/ 4 ft 5.5 in
	Overall length	L2	2002 (mm) 6 ft 6.8 in	2356 (mm) 7 ft 8.8 in	2650 (mm) 8 ft 8.3 in
	Length to face of forks	b1/b2	1152 (mm) 3 ft 9.4 in	1406 (mm) 4 ft 7.4 in	1700 (mm) 5 ft 6.9 in
	Overall width	s /e/l	846 (mm) 2 ft 9.3 in	846 (mm) 2 ft 9.3 in	990 (mm) 3 ft 3 in
	Fork dimensions DIN ISO 2331	Ast	32/ 100/ 850 (mm) 1.3 in/ 3.9 in/ 2 ft 9.5 in	32/ 100/ 950 (mm) 1.3 in/ 3.9 in/ 3 ft 1.4 in	35/ 100/ 950 (1070) (mm) 1.4 in/ 3.9 in/ 3 ft 1.4 in (3 ft 6.1 in)
	Aisle width for pallets 1000 × 1200 crossways	Ast	2610 (mm) 8 ft 6.8 in	2770 (mm) 9 ft 1.1 in	2950 (mm) 9 ft 8.1 in
	Aisle width for pallets 800 × 1200 lengthways	Wa	2750 (mm) 9 ft 0.3 in	2880 (mm) 9 ft 5.4 in	3070 (mm) 10 ft 0.9 in
Performance Data	Turning radius	km/h	1170 (mm) 3 ft 10 in	1334 (mm) 4 ft 4.5 in	1570 (mm) 5 ft 1.8 in
	Travel speed, laden/unladen	m/s	4.1/ 4.5	3.8/ 4.2	5.8/ 6.0
	Lift speed, laden/unladen	m/s	0.17/ 0.25	0.11/ 0.15	0- 0.12/ 0- 0.19
	Lowering speed, laden/unladen	%	0.14/ 0.14	0.08/ 0.09	0- 0.45
	Max. Gradeability, laden/unladen		6/ 10	5/ 10	6/ 10
	Service brake	kW	Electromagnetic	Electromagnetic	Electromagnetic
	Drive motor rating S2 60 min	kW	0.65 (DC)	0.65 (DC)	1.2 (AC)
Motors	Lift motor rating at S3 15%	(V)/(Ah) or kWh	2.2 (DC)	2.2 (DC)	4.5 (DC)
	Battery voltage/nominal capacity K5		24/ 105	24/ 125	24/ 280
	Battery weight	dB (A)	60.8 (kg) 134 (lb)	60.8 (kg) 134 (lb)	280 - 320 (kg) 617.3 - 705.5 (lb)
	Sound pressure level at the driver's seat		65	65	65

*Refer to Figure 1. for additional info for abbreviation references (eg. h14).